

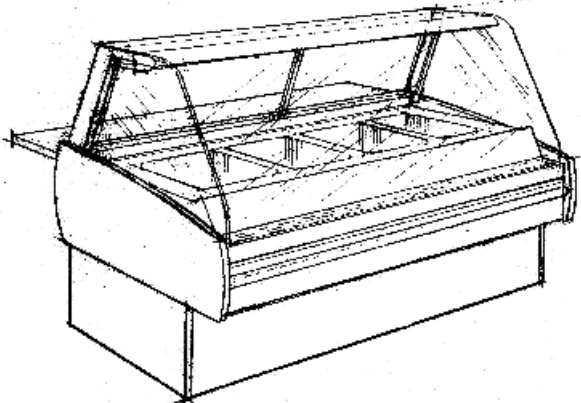

The Diamond 52 Series

HDE-HOT DELI CASE

ITEM # _____



*If Hot Deli cases are placed adjacent to refrigerated or dry cases, two divider glasses and one end panel must be specified between those cases to reduce condensation.

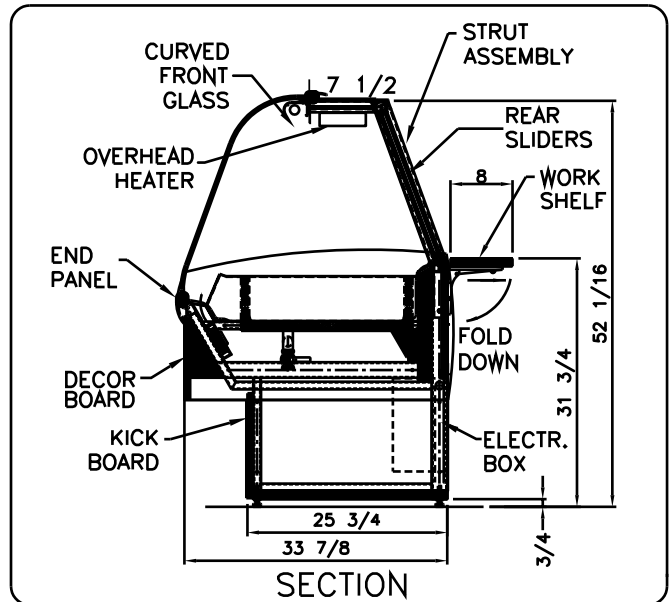

SPECS: Aluminum frame; leveling legs; series 300 stainless steel interior; epoxy point upper structure; anodized aluminum trim; .25 tempered end glass; tilt-out front glass STD.; lights w/ spectrum sleeves; 3/4" plywood finish millwork. ETL sanitation listed to NSF 4.

	Standard	Optional
EUROPEAN CURVED GLASS		
Tilt-Out Front Glass	<input type="checkbox"/>	<input type="checkbox"/>
Lift-Up Front Glass	<input type="checkbox"/>	<input type="checkbox"/>
Non-Glare Glass	<input type="checkbox"/>	<input type="checkbox"/>

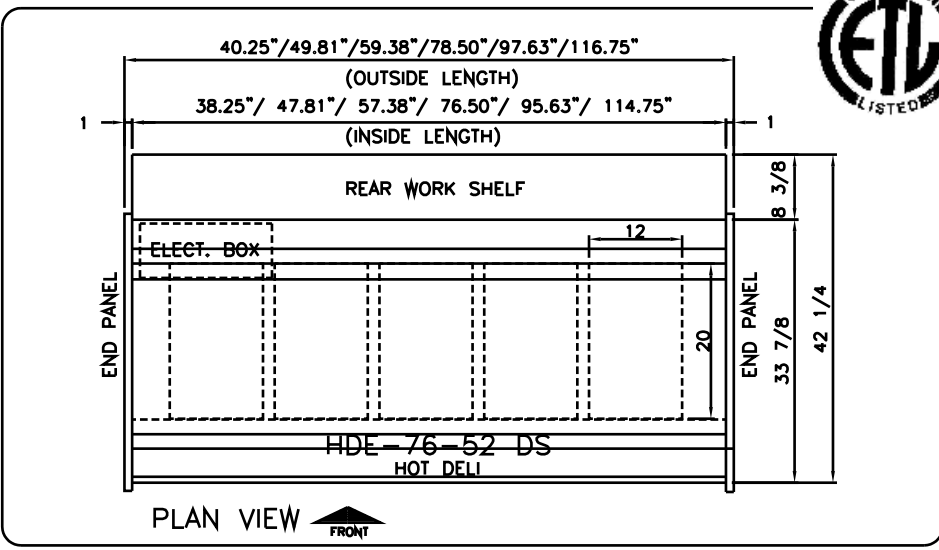

UPPER STRUCTURE		
Epoxy Point - White	<input type="checkbox"/>	
Epoxy Point - Black	<input type="checkbox"/>	
Epoxy Point - other colors	<input type="checkbox"/>	

ALUMINUM TRIM		
Chrome Anodized	<input type="checkbox"/>	
Brass Anodized	<input type="checkbox"/>	
Epoxy paint color	<input type="checkbox"/>	

END/ DIVIDER GLASS		
1/4" Tempered	<input type="checkbox"/>	
1/4" Temp.-Mirror Film	<input type="checkbox"/>	

SLIDING DOORS		
Clear Plexi	<input type="checkbox"/>	
Plexi w/ Mirror Film	<input type="checkbox"/>	

END PANELS/DECOR BD/KICKBD		
Pl.Laminate on Plywood	<input type="checkbox"/>	
Maple,Cherry,Oak Veneer	<input type="checkbox"/>	
Stainless Steel	<input type="checkbox"/>	

MODEL	LENGTH in mm	VOLTAGE HOT WELLS	AMPS HOT WELLS <input type="checkbox"/>	VOLTAGE O.H. HEATER	AMPS O.H. HEATER <input type="checkbox"/>
<input type="checkbox"/> HDE-38-52 DS	38.25" 972	230V/1/60	10.0	115V/1/60	6.0
<input type="checkbox"/> HDE-48-52 DS	47.81" 1214	230V/1/60	15.0	115V/1/60	8.4
<input type="checkbox"/> HDE-48-52 DS	57.38" 1457	230V/1/60	20.0	115V/1/60	11.0
<input type="checkbox"/> HDE-76-52 DS	76.50" 1943	230V/1/60	25.0	115V/1/60	15.4
<input type="checkbox"/> HDE-96-52 DS	95.63" 2429	230V/1/60	30.0	115V/1/60	16.8
<input type="checkbox"/> HDE-115-52DS	114.75" 2915	230V/1/60	35.0	115V/1/60	22.0

FOLD-DOWN REAR WORK SHELF		
Wilsonart Fr. White	<input type="checkbox"/>	
Saniboard	<input type="checkbox"/>	
Surell	<input type="checkbox"/>	
Stainless Steel	<input type="checkbox"/>	

EQUIPMENT		
Inside Defogging System	<input checked="" type="checkbox"/>	
AutoFill System	<input type="checkbox"/>	

Z:\Documents and Settings\All Users\Documents\cat203\diamond52\DWG\26-HDE.dwg, 7/15/2003 11:40:17 AM, Jayne Hurley