



EkoMax/EkoFlex SPECIFICATIONS & FINISHES

The **EkoMax Series** is Arctica's economical European style food display case, available **in up to six lengths and two display heights (52" & 48")**
>>>>EkoFlex only available in 52" height and two lengths (38.25" & 47.81")

CONSTRUCTION:

Sturdy, indestructible welded aluminum frame and upper structure epoxy powder coated in white or black. Kick board, décor board and 1" baltic plywood end panels in 8 standard plastic laminates. (See Color Chart)

>>>> New height and angle adjustable glass or wire shelves!

INTERIOR FINISH:

All metal parts in the refrigeration compartment (or hot cases) are made of 300 series stainless steel. Display inlays and air ducts are black or white epoxy powder coated.

REFRIGERATION SYSTEM: (ETL certified to new NSF Standard 7)

The display area is refrigerated on all levels (shelves) between 34 and 40F based on max. 90F ambient temperature. Slow moving fans and an oversized evaporator coil with over 5000 square inches of cooling surface per foot guarantee gentle cooling and quick recovery after defrost with up to 75% humidity. For higher humidity levels refer to **Arctica's humidification system. (Floor drain required with humidifier!)**

SELF-CONTAINED REFRIGERATION: (optional)

All Arctica cases are available for self-contained applications. The refrigeration system is based on CFC free R134a and has a built-in hot gas evaporator (no drains necessary). Compressors up to 1/2 HP are wired directly to Arctica's electrical control box (115V); 3/4 HP compressors require a separate circuit (220/208) to the main panel.
Remote cases are supplied with TXV, thermostat, timer and solenoid valve.

HUMIDIFICATION SYSTEM: (optional)

Arctica's unique self-cleaning ultra-sonic humidification system is the first nearly maintenance free humidifier on the market. With up to 90% humidity it provides the ultimate in product freshness, reducing dry-out losses significantly and extending product shelf life by more than 50%.

NOTE: An Arctica water treatment system for the supply line is recommended; in hard water conditions its mandatory. **Do not sell a humidifier without floor drain!**

DEFOGGING SYSTEM: (standard)

All refrigerated cases are fitted with a defogging system. The defogging system will keep the front and top glass clear of moisture in a controlled store environment not exceeding 75F and 55% relative humidity.

COLOR CORRECTED LIGHTS: (standard)

All Arctica cases are standard equipped with SPECTRUM sleeves to enhance the natural look of the product on display, providing true color rendition, glare reduction and UV protection. Use standard T8 cool white fluorescent light only.



EkoMax/EkoFlex SPECIFICATIONS & FINISHES

CURVED FRONT GLASS: (standard)

- Tempered .25" curved glass, standard tilt-out (tilt forward) **Lift-up optional!**

SHELF & SIDE GLASS: Tempered glass, .25", end glass mirror film optional. Glass shelves are standard. Painted (black or white) and brass or chrome wire shelves available as an option. **New height and angle adjustable glass and wire shelves now standard!**

SLIDING DOORS: 3/8" pet G plexi glass in aluminum frame, mirror film optional.

LIGHT CANOPIES / GLASS CLAMPS:

- Brass or chrome polished anodized aluminum standard. **No other options available!**

WARRANTY:

- All Arctica products are covered by a **ONE YEAR PARTS & LABOR** warranty.
- Refrigerated cases ordered with self-contained refrigeration system are automatically covered for an **additional four (4) years parts replacement for the motor compressor.** (For more information see pages 1 and 2 under General Information)

SAFETY & SANITATION APPROVALS:

All Arctica showcases are **ETL safety & sanitation listed to NSF standards 2, 4 or 7.**

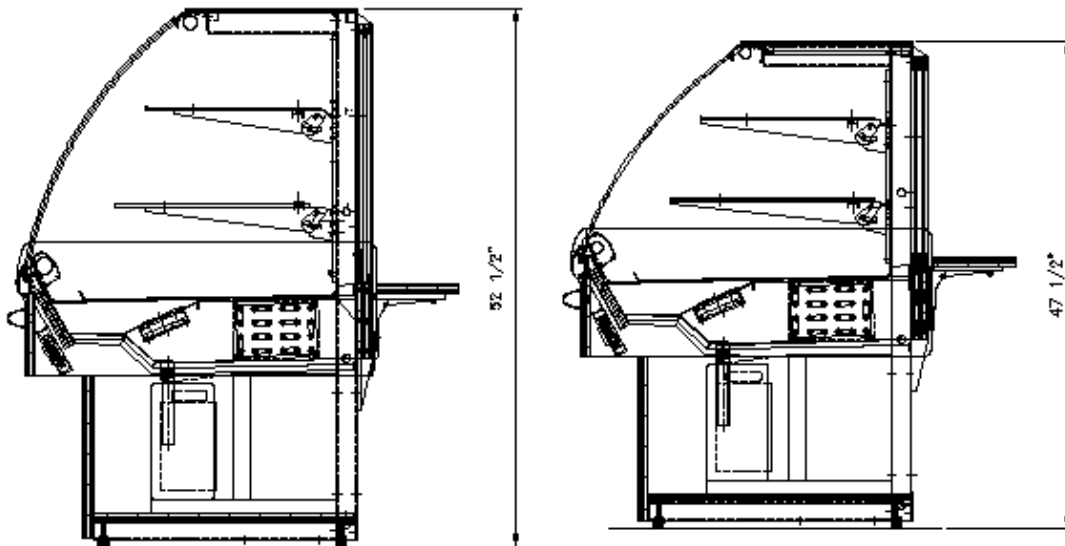

STANDARD SPECIFICATIONS & FINISHES

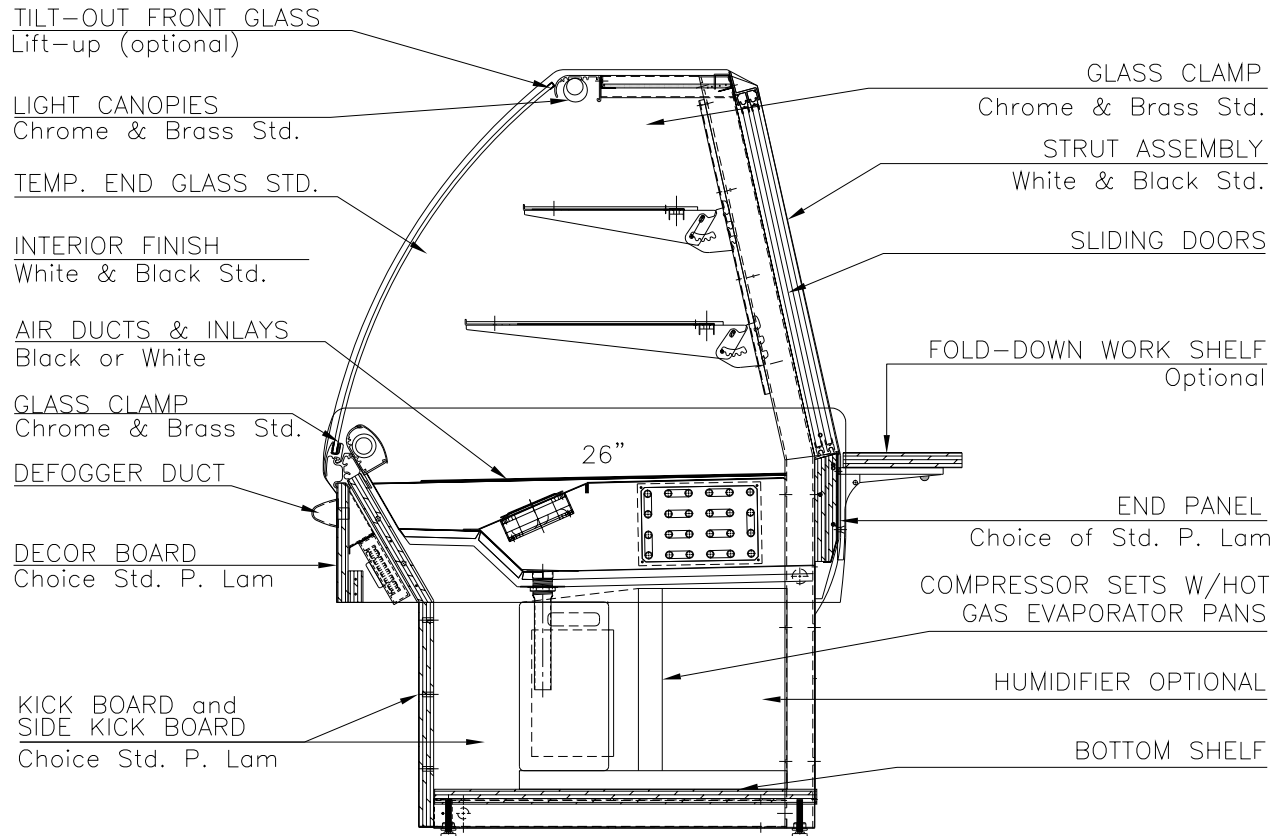

RST-REFRIGERATED STANDARD
STANDARD GLASS-LG
NG-NON GLARE (OPTIONAL)

STANDARD SPECIFICATIONS & FINISHES GELATO CASE

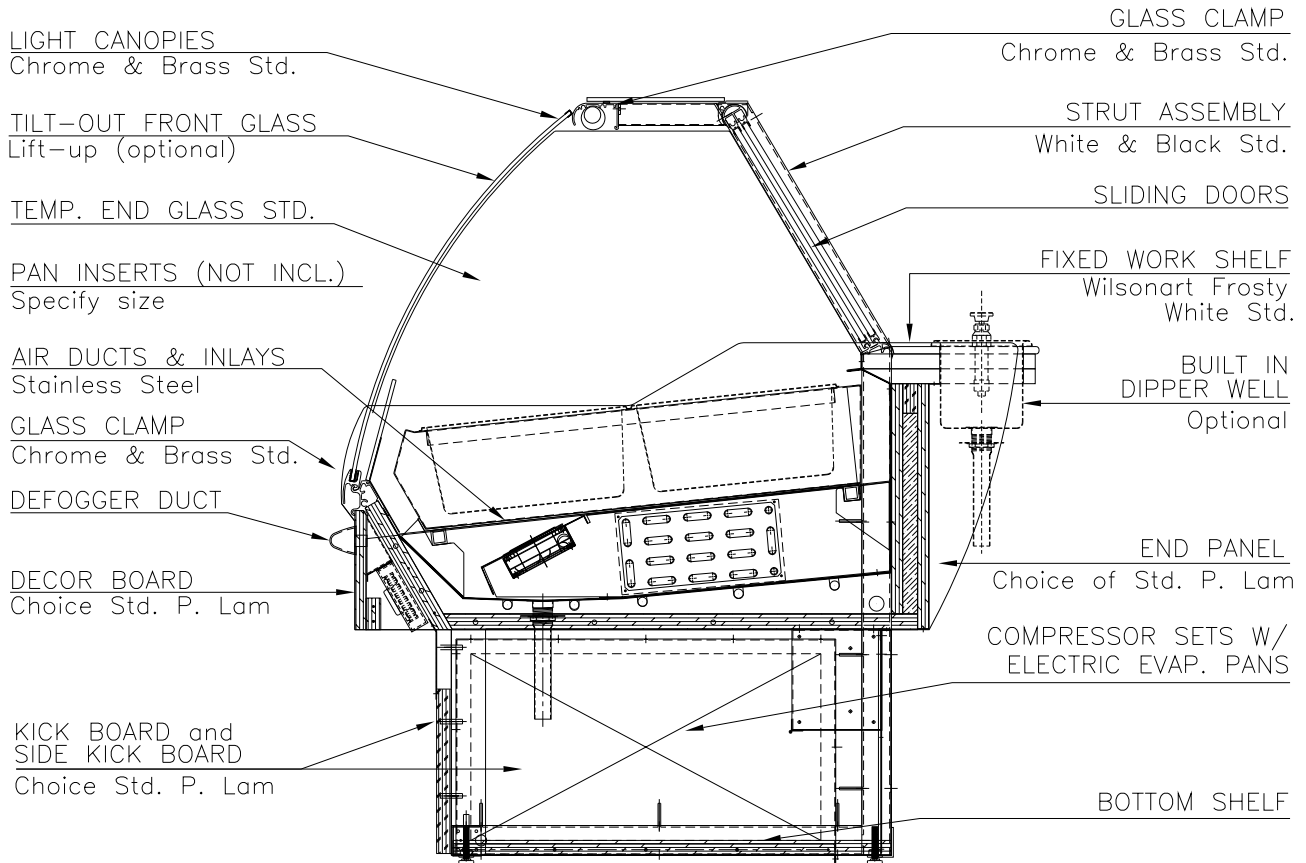

GEL-GELATO ICE CREAM DIPPING CABINET
STANDARD GLASS-LG
NON-GLARE-NG (OPT)